

# Technical Bulletin

## Torque Specs for Direct™ Plus, Flex, and Max

### Preventative Maintenance Torque Check

Purkeys would like to suggest that on all preventative maintenance checks or repairs to a Direct Plus, Flex, or Max, all threaded stud junctions be checked for proper tightness, as the nuts may loosen over time. To reduce the chance of loose fasteners, Purkeys has changed the design to incorporate Nylok nuts in future products.

The stud junctions shown below need to be checked. The minimum recommended torque specs are:

Call-out	Size	Recommended torque
1: circled in yellow	8/32	36 inch-lbs
2: circled in red	10/32	48 inch-lbs
3: circled in blue	1/4-20	60 inch-lbs

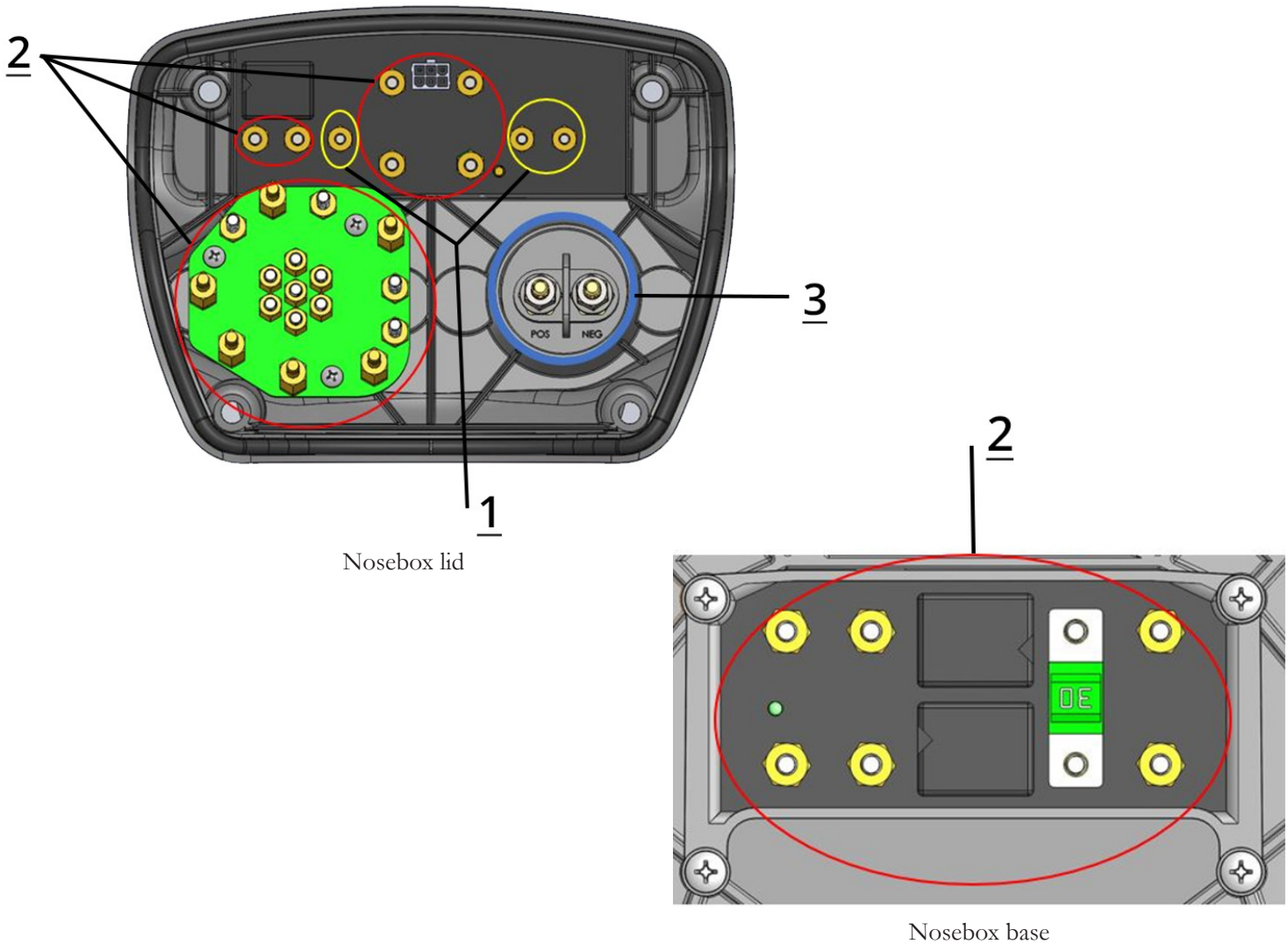

Please contact Purkeys' Technical Services Department if you have any questions.  
Phone: 479-419-4800 | [www.purkeys.net/contact/](http://www.purkeys.net/contact/)