

# PURKEYS

A MISSION CRITICAL ELECTRONICS BRAND

## DIRECT™ -02

---

# INSTALLATION GUIDE





# CONTENTS

---

General Information.....	2
Direct-02 Diagram .....	3
Mounting the Direct Controller .....	4
Main Harness Installation.....	5
Part List.....	9
Limited Commercial Warranty Policy .....	12

## GENERAL INFORMATION

---

The Purkeys Direct™ system improves the charging of liftgate batteries by utilizing a DC/DC Converter to boost the voltage for optimal charging. The boost in voltage overcomes the normal voltage drop caused by the extended distance between the liftgate batteries and the vehicle charging system. Also, in cold temperatures batteries require increased charging voltages to maintain a high state of charge. The DC/DC Converter in the Direct system compensates for temperature as well as for voltage drop and provides the best voltage to the remotely located liftgate batteries. The result is well-charged liftgate batteries that will last longer and have ample power for liftgate operation.

The Direct system is automatic and has easy to interpret LED indicators to assure drivers and technicians of proper system function. The Direct Controller increases the time that the DC/DC Converter can charge the liftgate batteries by monitoring the source power and “extending” the liftgate battery charge time to take full advantage of the available power, without compromising the source batteries’ ability to crank the engine. Simply put, the Direct system provides opportunity charging for the liftgate batteries that is essential in low mileage, high frequency liftgate operation applications. The LED indicators clearly show the status of the source as well as the status of the liftgate batteries. A quick glance at the Direct Controller assures the driver that the liftgate batteries are ready to go, or alerts the driver that the batteries need maintenance.

**NOTE:** Our liftgate charging systems are designed to work with flooded cell and AGM batteries. If you are using this system to charge any other type of battery, please contact us at 479-419-4800 before installation.

# DIRECT-02 INSTALLATION GUIDE

## DIRECT-02 DIAGRAM

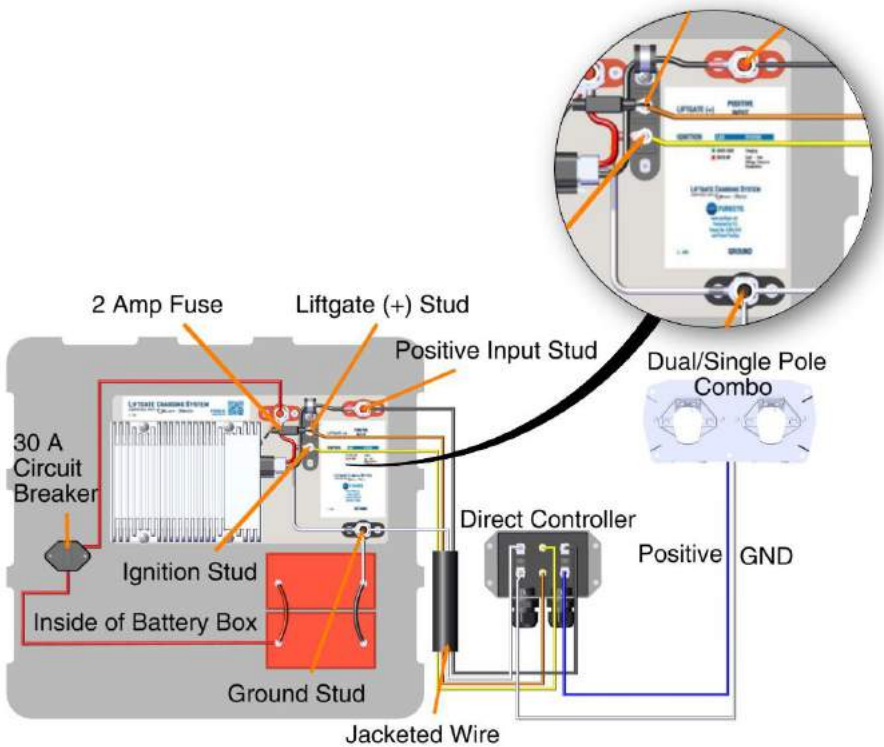

## MOUNTING THE DIRECT CONTROLLER

Step 1: Mount the Direct Controller at the front of the trailer via the mounting holes on the mounting plate.



Step 2: Mount the dual/single pole nosebox to the front of the trailer close to the Direct Controller. The connections to the Direct Controller have already been made.

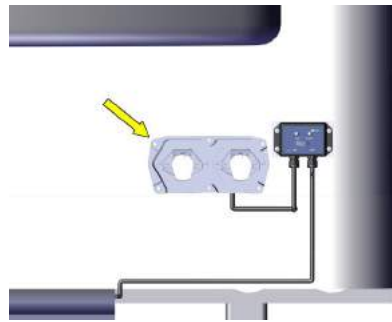

Note: Do not block the LED status decal on the side of the Direct when mounting the Direct Controller.



Note: The dual/single pole nosebox must be mounted with the wires facing down to help prevent water intrusion.

Direct Controller Mounting Complete.

# DIRECT-02 INSTALLATION GUIDE

## MAIN HARNESS INSTALLATION

Step 1: Route the Direct jacketed 4-conductor main harness for the DC/DC converter behind the front plate, then behind the header plate through the air/electrical tube to the center channel.

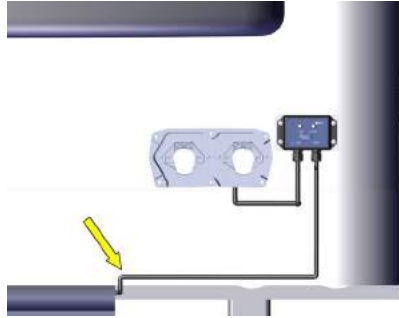

Step 2: Route the Direct jacketed 4-conductor main harness in the center channel toward the back of the trailer. Secure with wire ties or cable clamps as you go.



Note: Place the cable clamps along the 4-conductor jacketed main harness every 6 inches to ensure proper support for the cable. Avoid sharp edges and possible chaffing points.

Step 3: Once you are near the liftgate battery box, begin routing the Direct jacketed 4-conductor main harness into the liftgate battery box through a dome nut or rubber grommet.



Note: Ensure that the jacketed 4-conductor main harness enters the liftgate battery box through a dome nut or rubber grommet to prevent chaffing the harness, which could result in possible electrical short in the system.

Step 4: Position the Direct jacketed 4-conductor main harness so that it will reach the 2-stud strip and all the slack has been taken up. Mark the jacketed 4-conductor main harness so that it can be taken back out of the battery box to be terminated.

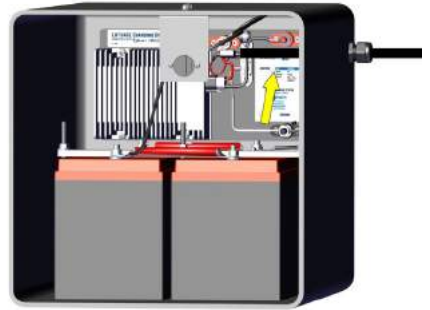

Note: If your battery box includes a slid-out tray, include enough slack to allow the tray to fully extend without tugging the wire connections.

Step 5: Pull the jacketed 4-conductor main harness out of the box (making it easier to work on), and cut off the excess at the mark.



Step 6: Cut about 8 inches off the jacketed portion of the 4 wires.

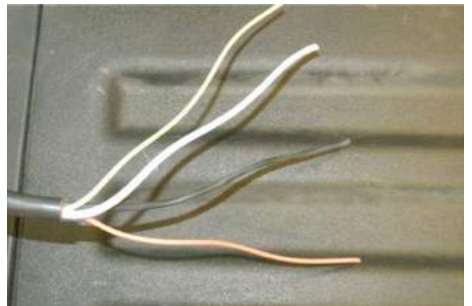



## DIRECT-02 INSTALLATION GUIDE

Step 7: Apply the supplied 1/2 inch black heat shrink where the jacket was stripped off.

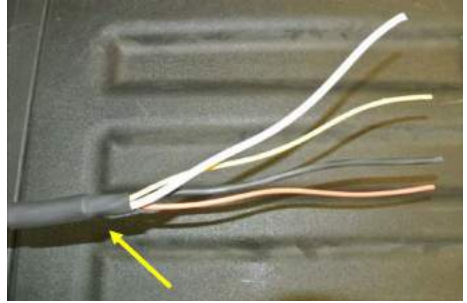

Step 8: Strip 3/8 inch of insulation off all 4 wires.

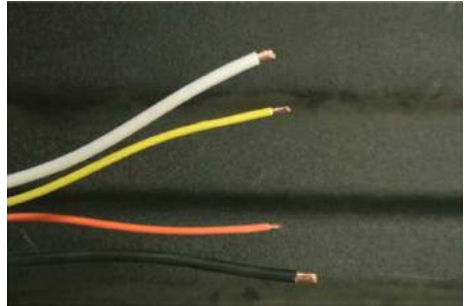

Step 9: Slide the supplied 1/2 inch red heat shrink over the orange, yellow, and black wires. Slide the supplied 1/2 inch black heat shrink over the white wire.

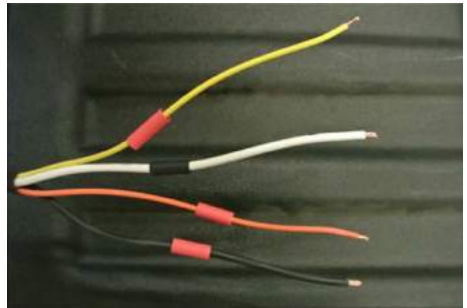

Step 10: Crimp 3/8 ring terminals onto the white and black 8-gauge wires. Crimp #10 ring terminals onto the 14-gauge orange and 16-gauge yellow wires.

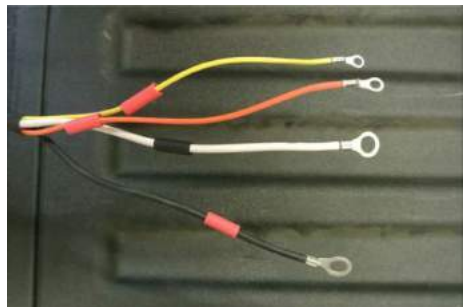

Step 11: Position the heat shrink over the crimps and apply heat to the 4 terminals.

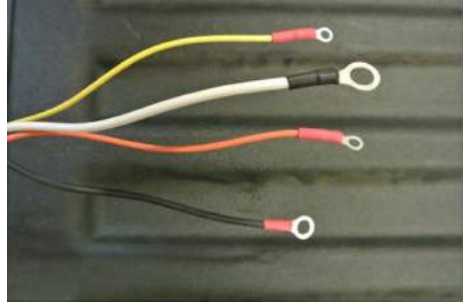

Step 12: Re-route the jacketed 4-conductor main harness back into the battery box (see diagram on page 3 for stud location).

- Connect the 8-gauge black wire to the red positive input stud.
- Connect the 8-gauge white wire to the black ground stud.
- Connect the 14-gauge orange wire to the liftgate (+) stud.
- Connect the 16-gauge yellow wire to the ignition stud.

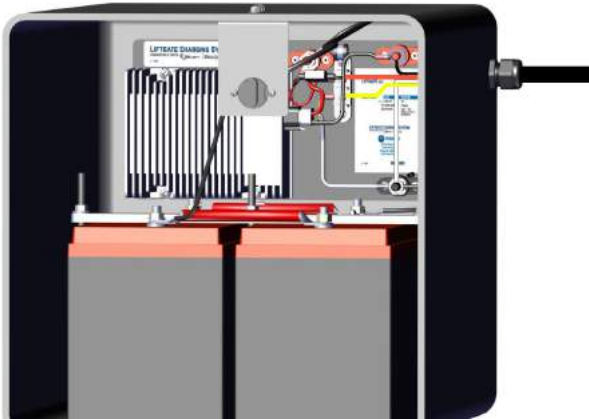

Main Harness Installation Complete.

# DIRECT-02 INSTALLATION GUIDE

## PART LIST



PART# MOD00077  
DIRECT CONTROLLER  
REPLACEMENT



PART# H-00286  
50 FT MAIN HARNESS

PART# H-00315  
70 FT MAIN HARNESS

PART# H-00314  
25 FT MAIN HARNESS



PART# NB00036  
DUAL/SINGLE POLE NOSEBOX



**PART# BK-1049 (Revision B)**  
**TERMINAL BAG KIT**



**PART# BK-1054 (Revision B)**  
**HARDWARE BAG KIT**



**PART# DIRECT-02**  
**DIRECT WITH DUAL COMBO**  
**CONNECTION 50' HARNESS**

**PART# DIRECT-02-70**  
**DIRECT WITH DUAL COMBO**  
**CONNECTION 70' HARNESS**

# DIRECT-02 INSTALLATION GUIDE



PART# F00062  
30 AMP MIDI FUSE

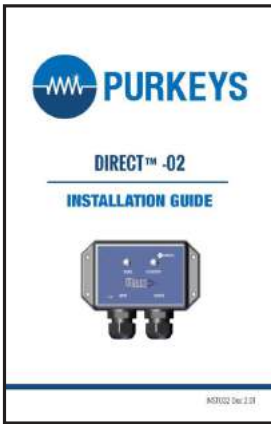

PART# INST032  
DIRECT-02 INSTALLATION  
GUIDE

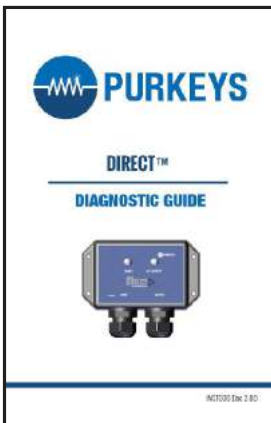

PART# INST030  
DIRECT DIAGNOSTIC GUIDE

## LIMITED COMMERCIAL WARRANTY POLICY

---

MCE Purkeys FE, LLC (hereafter “Purkeys”), warrants each product to be free of defects in material or workmanship under normal use and service. This warranty is for the benefit of Original Equipment Manufacturers, Dealers, Warehouse Distributors, Fleets, or other End Users (hereafter “Customers”) and covers products manufactured by Purkeys and sold new to Customers either directly by Purkeys or by its authorized dealers, distributors, or agents. The length of the Warranty Period is 36 months.

The warranty period commences on the in-service or install date and is not transferable. Failure to provide the in-service or install date on the warranty claim form will cause the warranty period to begin on the date the part was manufactured, or date of sale recorded on the original sales invoice, whichever is earlier.

A completed warranty claim form should accompany all parts submitted to Purkeys for consideration for repair or replacement under warranty. The submitted claim form should contain all of the information required. Lack of a properly or fully completed claim form will result in delay or denial of warranty claim. Claims must be submitted no later than 30 days after part is removed.

This warranty does not apply if, in sole judgement of Purkeys, the product has been damaged or subjected to accident, faulty repair, improper adjustment, improper installation or wiring, neglect, misuse, or alteration or if the product failure is caused by defects in peripheral vehicle components or components attached to the Product or failure of a part not manufactured by Purkeys.

This warranty shall not apply if any Purkeys product is used for a purpose for which it is not designed or is in any way altered without the specific prior written consent of Purkeys. ANY product alleged by a Customer to be defective must be inspected by Purkeys as a part of the warranty claims process in order to confirm that the part has failed as a result of a defect in material or workmanship.

Transportation for products and parts submitted to Purkeys for warranty consideration must be prepaid by Customer. Repaired or replaced products and/or components will be returned to Customer pre-paid by Customer or “freight collect” to the address provided by Customer in the warranty claim form. No charge will be made for labor or material in effecting such repairs.

The Warranty provided by Purkeys hereunder is specifically limited to repair or replacement of the Product as Purkeys deems most appropriate in its sole discretion. Purkeys neither assumes nor authorizes any other person to assume on its behalf any other warranty or liabilities in connection with Purkeys products. The Warranty does not apply to fuses or other “consumable” or maintenance items which are or may be a part of any Purkeys product.

**THIS WARRANTY DOES NOT APPLY TO LOSS OF VEHICLE OR EQUIPMENT, LOSS OF TIME, INCONVENIENCE, OR OTHER INCIDENTAL OR CONSEQUENTIAL DAMAGES. PURKEYS SPECIFICALLY DISCLAIMS AND SHALL NOT BE LIABLE FOR INCIDENTAL OR CONSEQUENTIAL DAMAGES arising out of or from the use of Purkeys products by the Customer.**

**THIS LIMITED WARRANTY IS IN LIEU OF ALL OTHER WARRANTIES, INCLUDING COMMON LAW WARRANTIES OF FITNESS FOR A PARTICULAR PURPOSE, MERCHANTABILITY, AND ANY OTHER EXPRESS OR IMPLIED WARRANTIES. ALL OTHER SUCH WARRANTIES ARE SPECIFICALLY DISCLAIMED.**

This Limited Commercial Warranty supersedes all previous Warranty Policies issued by Purkeys and any of its suppliers.

# DIRECT-02 INSTALLATION GUIDE



***WATT Keeps You Trucking***