

# PURKEYS

A MISSION CRITICAL ELECTRONICS BRAND

## SEVERE SERVICE REEFER LINK

---

### INSTALLATION GUIDE





# CONTENTS

---

General Information .....	2
Reefer Option 1: Diagram .....	3
Reefer Option 1: Thermo King Charge Cable Installation .....	4
Reefer Option 1: Thermo King Excite/Remote Sense Harness Installation.....	6
Reefer Option 2: Diagram .....	8
Reefer Option 2: Carrier Vector Charge Cable Installation.....	9
Limited Commercial Warranty Policy.....	11

## GENERAL INFORMATION

---

The Purkeys' Select™ charging system can be enhanced for Severe Service applications by being paired with a parallel circuit powered by a dual pole or reefer connection. The Purkeys' Severe Service Kit provides an added route for power to travel to the trailer liftgate batteries. This kit works seamlessly in conjunction with the Select system.

The Select uses two-stage battery charging: bulk charging and topping off. When a trailer is equipped with a Severe Service Kit, the dual pole and/or reefer alternator helps during the early stages of bulk charging (when the battery is low or right after the liftgate is operated). As the battery state of charge increases, the Select takes over the charging until the batteries are fully charged. This occurs because the voltage level supplied by the dual pole alone is not as capable of topping off the charge of the liftgate batteries. The Select in parallel with the dual pole and/or reefer alternator assures that both the bulk charging and topping off of the liftgate batteries are optimized.



Severe Service Reefer Link installation will vary based on reefer manufacturer and model. The reefer unit must have liftgate charging capability and a previously installed Severe Service Trailer Link.

Choose the correct application from the options below:

Option 1: Thermo King Precedent Reefer with one internal charger and supplemental power package (accessory alternator). See Diagram on page 3.

Option 2: Carrier Vector 8600MT Reefer with two internal chargers and no alternator. See Diagram on page 8.

# SEVERE SERVER REEFER LINK

## REEFER OPTION 1: DIAGRAM

Option 1: Thermo King Precedent Reefer with one internal charger and supplemental power package (accessory alternator).

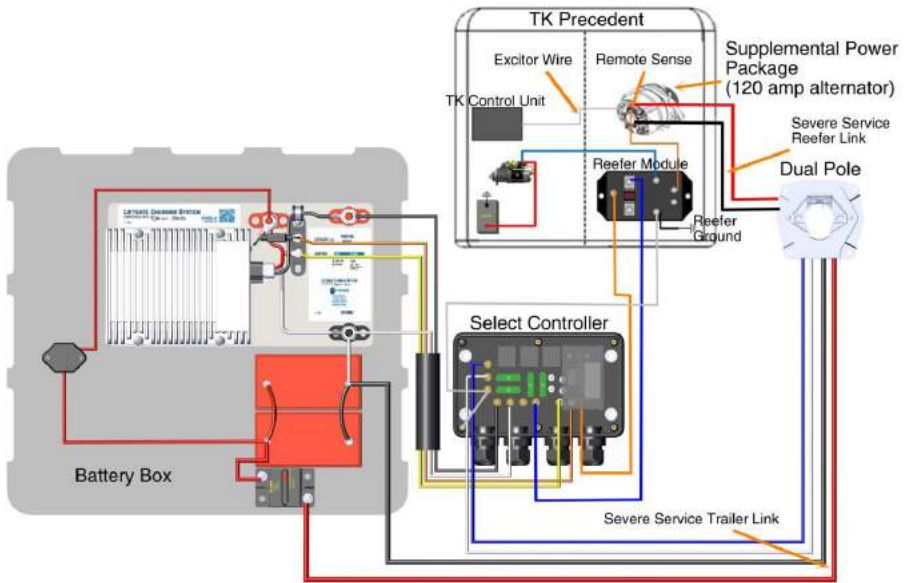

## REEFER OPTION 1: THERMO KING CHARGE CABLE INSTALLATION

---

Step 1: Connect the positive and negative Severe Service Reefer Link cables to the reefer alternator and tighten.

Note: Make sure that the liftgate charge cables are installed before any other cables are connected to these studs. This will help prevent the smaller terminations from failing due to current flowing through them first. Also make sure cables are not putting any stress on the alternator studs.

Step 2: Remove the lower screw and nut on the alternator mounting hinge and discard. Install the new supplied M8 screw. Open both clamps, and insert cables into the individual clamps. Install M8 washer and nut, then tighten.

Step 3: Mount the supplied butterfly cable tie to the reefer frame using the supplied M6 screw or self tapping screws.

Step 4: Secure the positive cable on one side of the cable tie and the negative cable on the opposite side of the cable tie.

Step 5: Route the positive and negative charge cables toward the dual pole nosebox on the front of the trailer. Secure to the trailer wall using the supplied butterfly cable ties every 6 inches.

Step 6: Remove the dual pole receptacle from the trailer wall to access the inside connections.



Step 7: Attach the positive charge cable to the positive side of the dual pole receptacle. Attach the negative charge cable to the negative side of the dual pole receptacle.

## **SEVERE SERVER REEFER LINK**

Note: It may be necessary to use the supplied ¼”-20 x ¾” bolts in place of the existing dual pole cable mounting bolts, as the existing bolts may not be long enough.

Step 8: Secure the dual pole nosebox back onto the trailer wall.

Installation Complete.

## REEFER OPTION 1: THERMO KING EXCITE/ REMOTE SENSE HARNESS INSTALLATION

NOTE: Thermo King Precedent Models C-600, C-600M, S-600, S-700, S-600M, S-600DE, S-610M, and S-610DE that are equipped with a battery charger must have the supplemental power package installed prior to connecting any external loads, including the Purkeys Select system. Connecting external loads directly to the reefer battery or any part of the TRU system MAY VOID the Reefer Unit warranty.

Installers MUST follow the step-by step procedures outlined in the Trailer Installation Manual TK 55681-11-IM (Rev.6,04/17) Battery Charger Kits and Supplemental Power Package Retrofit Kits.

It will be necessary to reconfigure the reefer unit to accept the supplemental power package (see following images).

### Reconfiguring the SR4 Controller

#### Reconfiguring the SR4 Controller

The unit will need to be reconfigured after removing an alternator and installing a battery charger or when adding supplemental power package.

1. In HMI Guarded Access go to **Hardware Configuration**.
2. Select **Choices** (NONE, 30 Amp, 120 Amp)
  - Select NONE - If the unit is equipped with an alternator.
  - Select 30 Amp - If the unit is equipped with a 30 Amp battery charger.
  - Select 120 Amp - If the unit is equipped with a 120 Amp battery charger.

**NOTE: If no choice is selected, the default is NONE.**

3. If you installed the supplemental power 120A stand alone alternator you must go to the Aftermarket Alternator and turn it on.

#### Troubleshooting

1. Make battery connections.
2. Rewire when necessary.
3. Make system ground.
4. Check for power.

Image from: Thermo King Trailer Installation Manual TK55681-11-IM, Battery Charger Kits and Supplemental Power Package Retrofit Kits.



# SEVERE SERVER REEFER LINK

## Sense Harness Installation

9. Attach sense harness 2-pin connector (SENSE, EXC) onto alternator.
10. Route single (EXC) wire into control box:
  - Insert (EXC) wire into pin C on the 3-pin connector (BCE-02) located on the battery charger harness installed earlier.
  - Attach 3-pin connector (BCE-02) to the mating connector (2Y-02, EXC-02) located inside the control box.
11. Route single (SENSE) wire to accessory positive (+) battery power.  
**DO NOT connect this to unit's battery.**

**IMPORTANT:** Connect SENSE wire to the correct accessory battery if

Image from: Thermo King Trailer Installation Manual TK55681-11-IM, Battery Charger Kits and Supplemental Power Package Retrofit Kits.

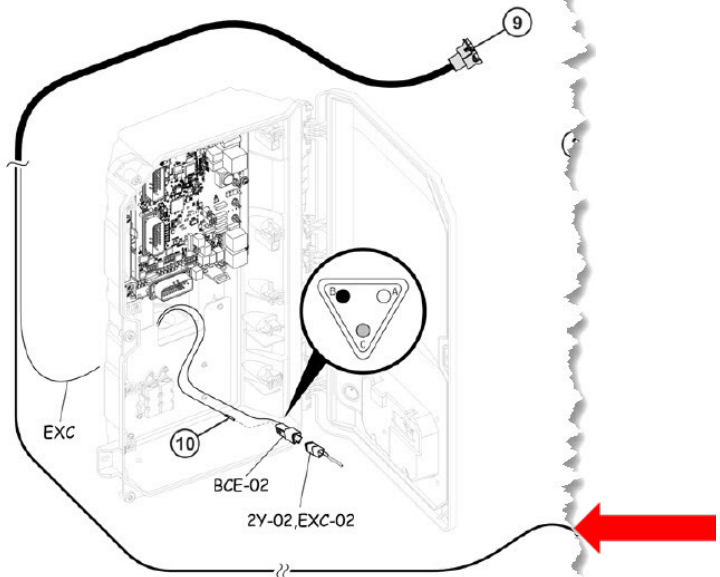
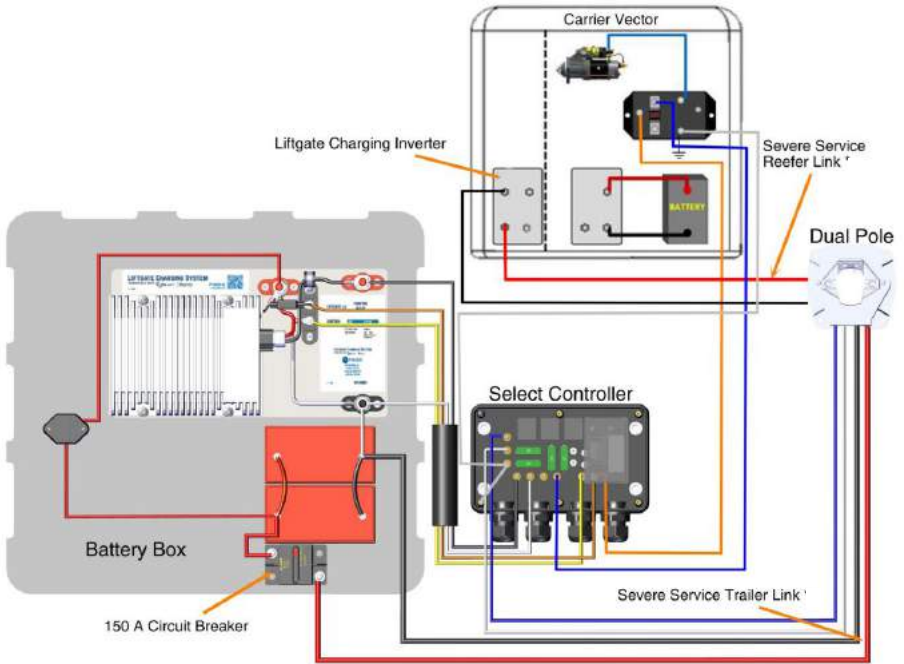

Image from: Thermo King Trailer Installation Manual TK55681-11-IM, Battery Charger Kits and Supplemental Power Package Retrofit Kits.

Installation Complete.

## REEFER OPTION 2: DIAGRAM

Option 2: Carrier Vector 8600MT reefer with two internal chargers and no alternator.



# SEVERE SERVER REEFER LINK

## REEFER OPTION 2: CARRIER VECTOR CHARGE CABLE INSTALLATION

Step 1: Connect the positive and negative Severe Service Reefer Link cables to the reefer inverter and tighten.

Note: Make sure that the liftgate charge cables are installed before any other cables are connected to these studs. This will help prevent the smaller terminations from failing due to current flowing through them first. Also make sure cables are not putting any stress on the liftgate charging or inverter studs.

Step 2: Connect the severe service reefer ground cable to the dedicated liftgate charging inverter ground connection and tighten.



Note: On Carrier Vector reefers with two charging inverters, the reefer harness must be installed on the liftgate charging inverter and not the reefer battery inverter. Looking up from the bottom of the reefer unit, the liftgate charging inverter is the one on the left.

Step 3: Connect the severe service reefer positive cable to the dedicated liftgate charging positive connection and tighten.



Note: Make sure no wire is left hanging and that all clamps and cable ties are no further than 6 inches away from each other.

Step 4: Route the positive and negative charge cables toward the dual pole nosebox on the front of the trailer. Secure to the trailer wall using the supplied butterfly cable ties every 6 inches.

Step 5: Remove the dual pole receptacle from the trailer wall to access the inside connections.



Step 6: Attach the positive charge cable to the positive side of the dual pole receptacle. Attach the negative charge cable to the negative side of the dual pole receptacle.

Note: It may be necessary to use the supplied  $\frac{1}{4}$ "-20 x  $\frac{3}{4}$ " bolts in place of the existing dual pole cable mounting bolts, as the existing bolts may not be long enough.

Step 7: Secure the dual pole nosebox back onto the trailer wall.

Installation Complete.

# SEVERE SERVER REEFER LINK

## LIMITED COMMERCIAL WARRANTY POLICY

---

MCE Purkeys FE, LLC (hereafter “Purkeys”), warrants each product to be free of defects in material or workmanship under normal use and service. This warranty is for the benefit of Original Equipment Manufacturers, Dealers, Warehouse Distributors, Fleets, or other End Users (hereafter “Customers”) and covers products manufactured by Purkeys and sold new to Customers either directly by Purkeys or by its authorized dealers, distributors, or agents. The length of the Warranty Period is 36 months.

The warranty period commences on the in-service or install date and is not transferable. Failure to provide the in-service or install date on the warranty claim form will cause the warranty period to begin on the date the part was manufactured, or date of sale recorded on the original sales invoice, whichever is earlier.

A completed warranty claim form should accompany all parts submitted to Purkeys for consideration for repair or replacement under warranty. The submitted claim form should contain all of the information required. Lack of a properly or fully completed claim form will result in delay or denial of warranty claim. Claims must be submitted no later than 30 days after part is removed.

This warranty does not apply if, in sole judgement of Purkeys, the product has been damaged or subjected to accident, faulty repair, improper adjustment, improper installation or wiring, neglect, misuse, or alteration or if the product failure is caused by defects in peripheral vehicle components or components attached to the Product or failure of a part not manufactured by Purkeys.

This warranty shall not apply if any Purkeys product is used for a purpose for which it is not designed or is in any way altered without the specific prior written consent of Purkeys. ANY product alleged by a Customer to be defective must be inspected by Purkeys as a part of the warranty claims process in order to confirm that the part has failed as a result of a defect in material or workmanship.

Transportation for products and parts submitted to Purkeys for warranty consideration must be prepaid by Customer. Repaired or replaced products and or components will be returned to Customer pre-paid by Customer or “freight collect” to the address provided by Customer in the warranty claim form. No charge will be made for labor or material in effecting such repairs.

The Warranty provided by Purkeys hereunder is specifically limited to repair or replacement of the Product as Purkeys deems most appropriate in its sole discretion. Purkeys neither assumes nor authorizes any other person to assume on its behalf any other warranty or liabilities in connection with Purkeys products. The Warranty does not apply to fuses or other “consumable” or maintenance items which are or may be a part of any Purkeys product.

**THIS WARRANTY DOES NOT APPLY TO LOSS OF VEHICLE OR EQUIPMENT, LOSS OF TIME, INCONVENIENCE, OR OTHER INCIDENTAL OR CONSEQUENTIAL DAMAGES. PURKEYS SPECIFICALLY DISCLAIMS AND SHALL NOT BE LIABLE FOR INCIDENTAL OR CONSEQUENTIAL DAMAGES arising out of or from the use of Purkeys products by the Customer.**

**THIS LIMITED WARRANTY IS IN LIEU OF ALL OTHER WARRANTIES, INCLUDING COMMON LAW WARRANTIES OF FITNESS FOR A PARTICULAR PURPOSE, MERCHANTABILITY, AND ANY OTHER EXPRESS OR IMPLIED WARRANTIES. ALL OTHER SUCH WARRANTIES ARE SPECIFICALLY DISCLAIMED.**

This Limited Commercial Warranty supersedes all previous Warranty Policies issued by Purkeys and any of its suppliers.

# SEVERE SERVER REEFER LINK

