



TAPSTM Pallet Jack Charger

Trailer Auxiliary Power System: Pure Sine Wave, 12.4 LVD

Purkeys' Trailer Auxiliary Power System (TAPS)[™] provides reliable AC power for commercial trailers. It allows drivers to power tools and equipment, such as electric pallet jacks, while on their routes rather than having to return to the warehouse or unload by hand.

Featuring a pure sine wave output, the TAPS creates an easy solution to power needs in the back of the trailer.

For features and benefits see page 4.



Specifications:

Meets IP66.....	Yes	Startup/Turn on Voltage.....	13.2 VDC
Continuous Output Power.....	see chart below	Low Voltage Disconnect Shutoff Voltage.....	12.4 VDC
Surge Power.....	3000 W	Quiescent Current.....	<25 mA
Output Voltage (Pure Sine).....	103.5-126.5 VAC	Efficiency.....	> 86%
(Nominal: 115 VAC)		Conduit diameter.....	.810 inches
Operating Voltage.....	12.4-16 VDC	Operating Temperature.....	see chart below

Output Based on Temperature:

The the graph below, the inverter will function at 100% duty cycle in the area under the line. In the area above the line, the inverter will run a reduced duty cycle—the further from the line in either temperature or output wattage, the more reduced the duty cycle will be.

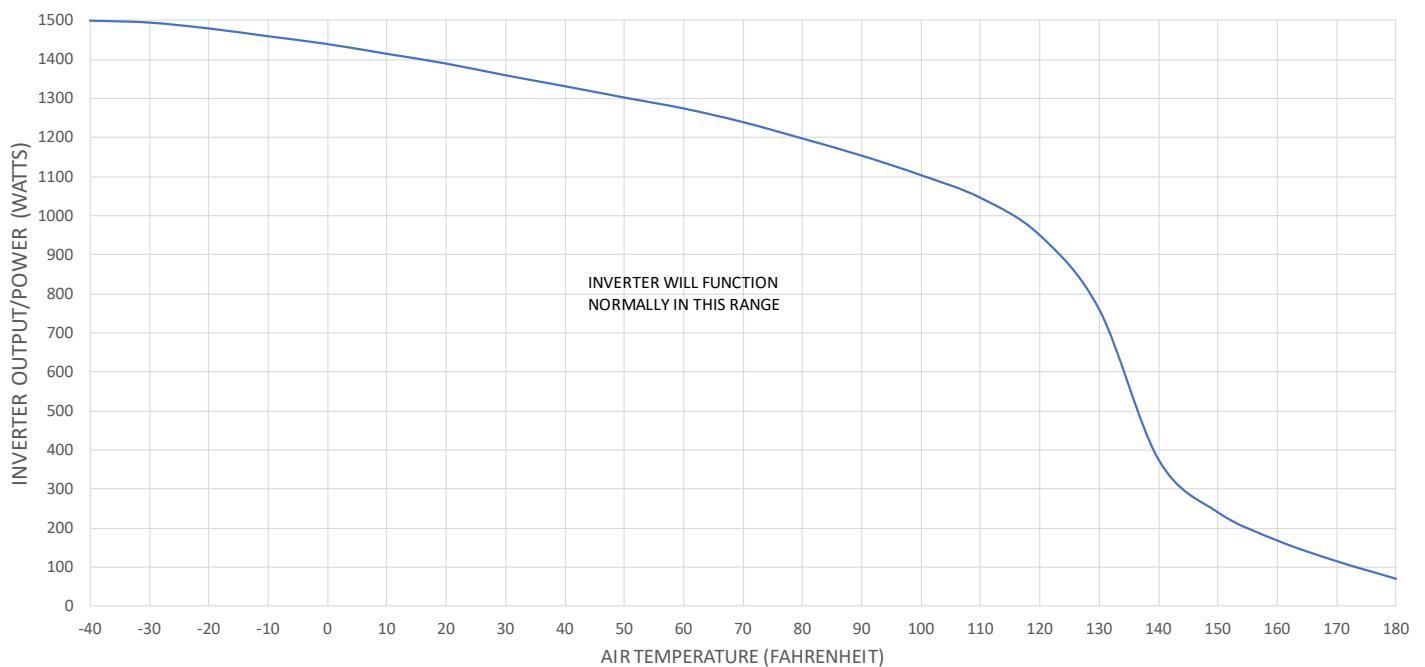

Dimensions:

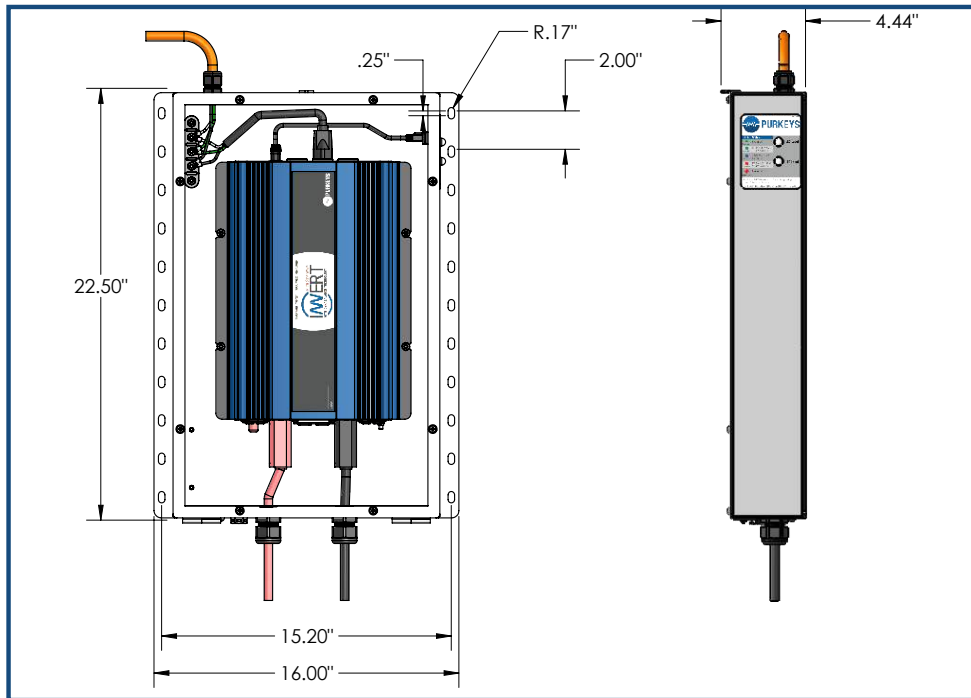

Call-outs: TAPS-300 Power System, 1500 W with Dual Pole 12.4 LVD

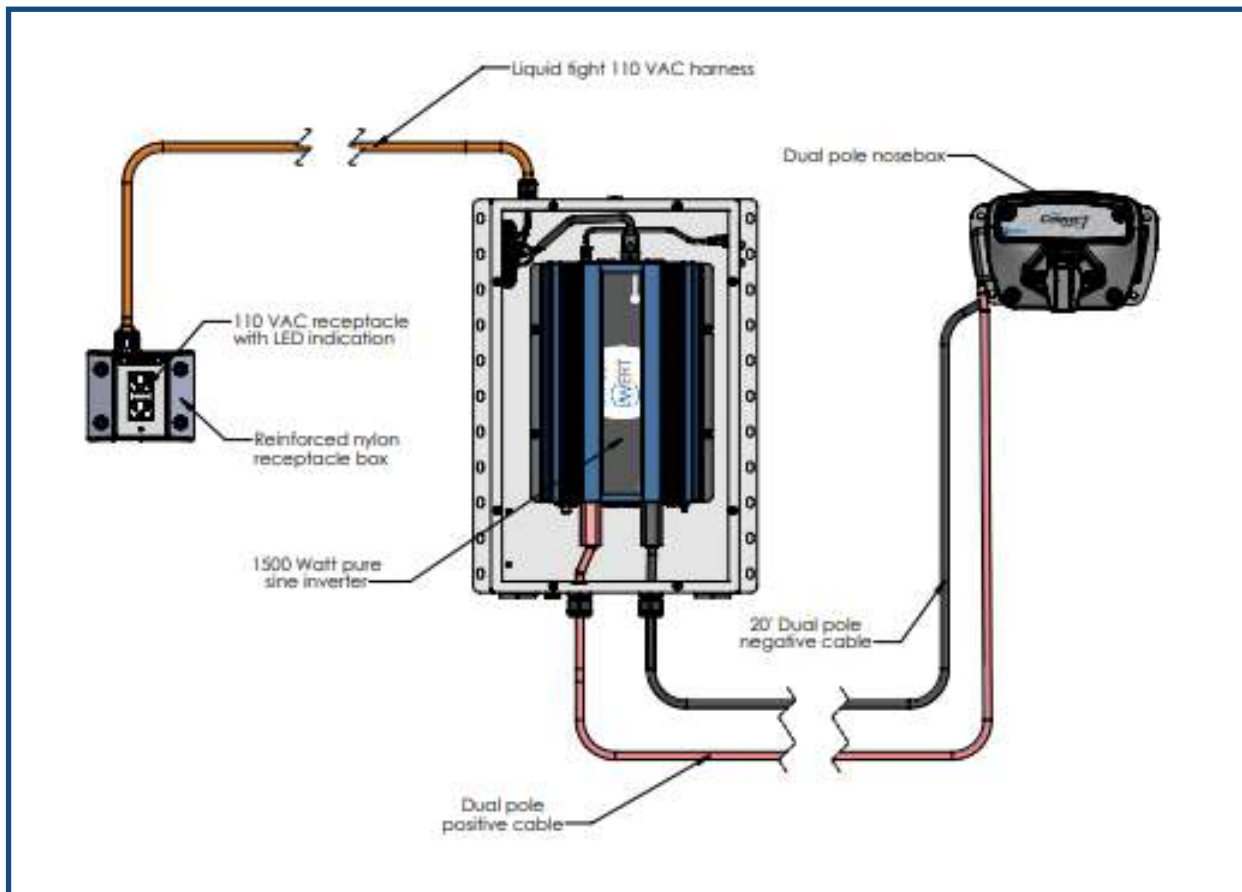

Call-outs: TAPS-301 Power System, 1500 W w/o Dual Pole 12.4 LVD, Straight Truck Application

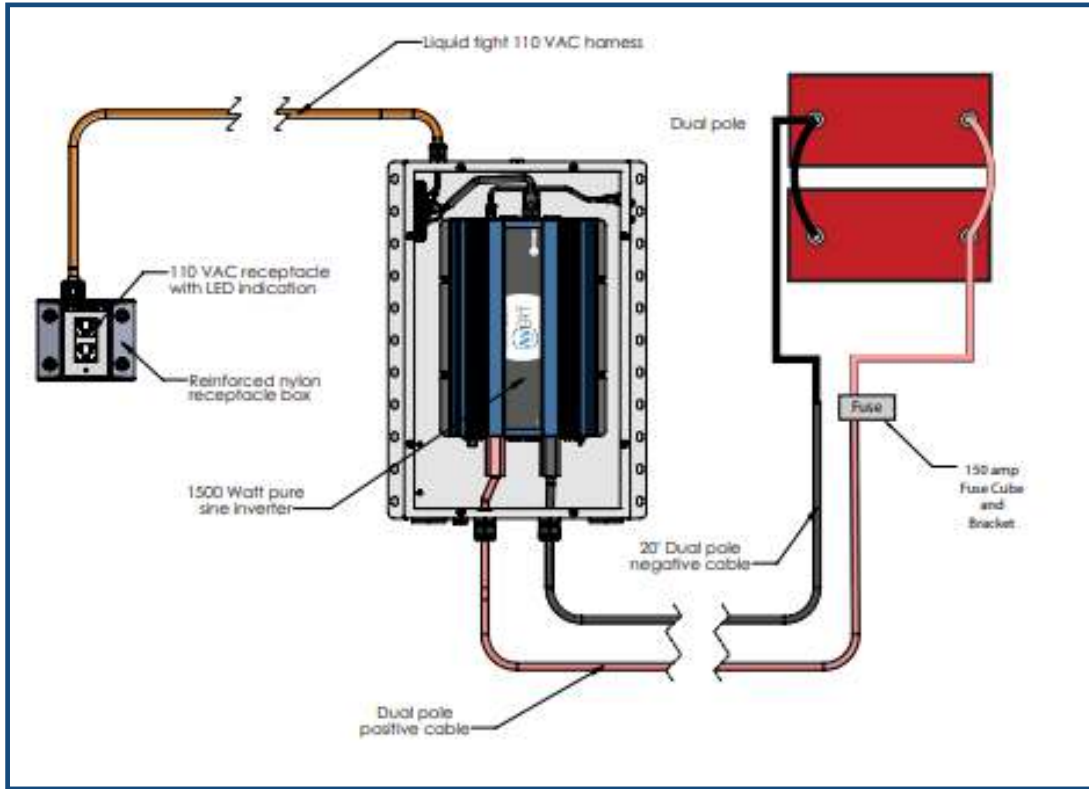

Call-outs: TAPS-304 Power System, 1500 W w/o Dual Pole 12.4 LVD, Existing Connection

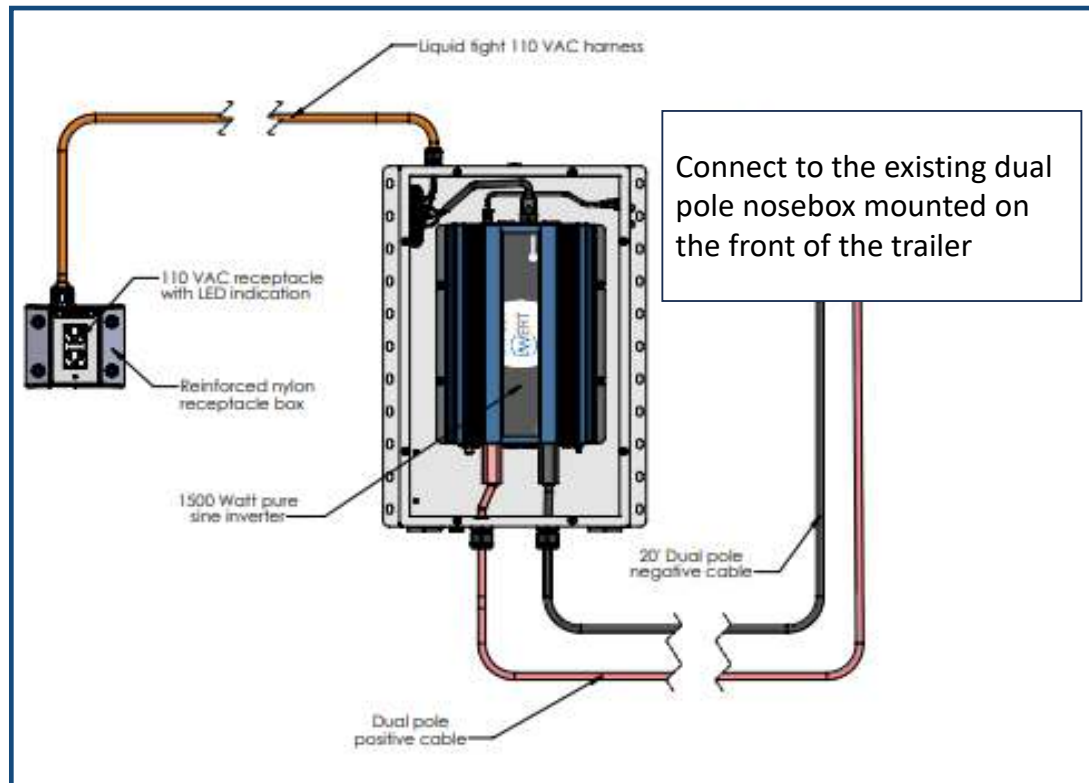

Part Numbers:

Part #	Description	Shipping size	Shipping weight
TAPS-300	TAPS for Dual Pole Applications	28 X 20 X 13	75 Lbs
TAPS-301	TAPS for Straight Truck Applications	28 X 20 X 13	75 Lbs
TAPS-304	TAPS without Dual Pole	28 X 20 X 13	75 Lbs

Nylon Outlet Box & Dimensions:



Nylon outlet box. Part number 100-5.

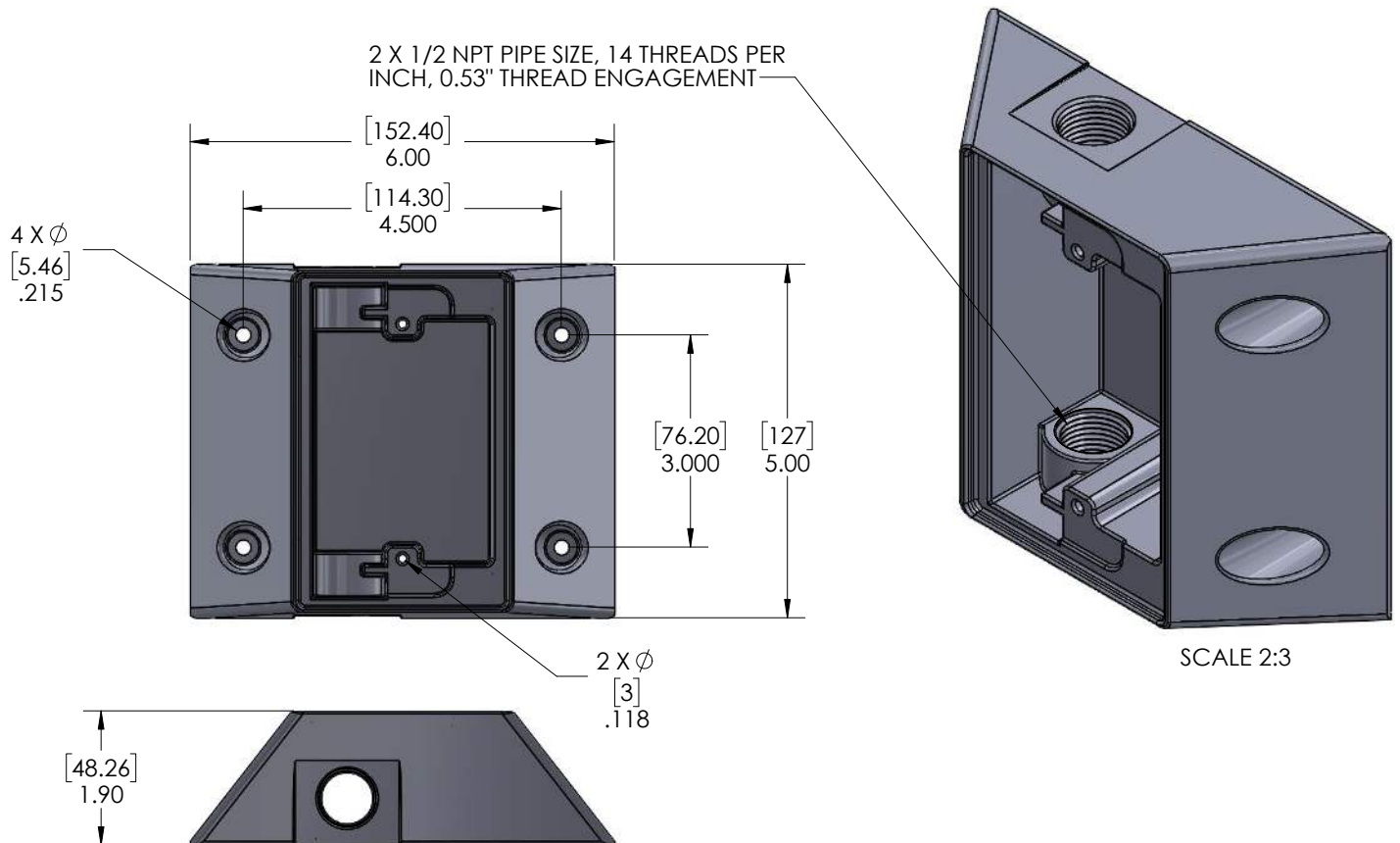

Recessed Nylon Outlet Box & Dimensions:



Nylon outlet box, recessed. Part number 100-83

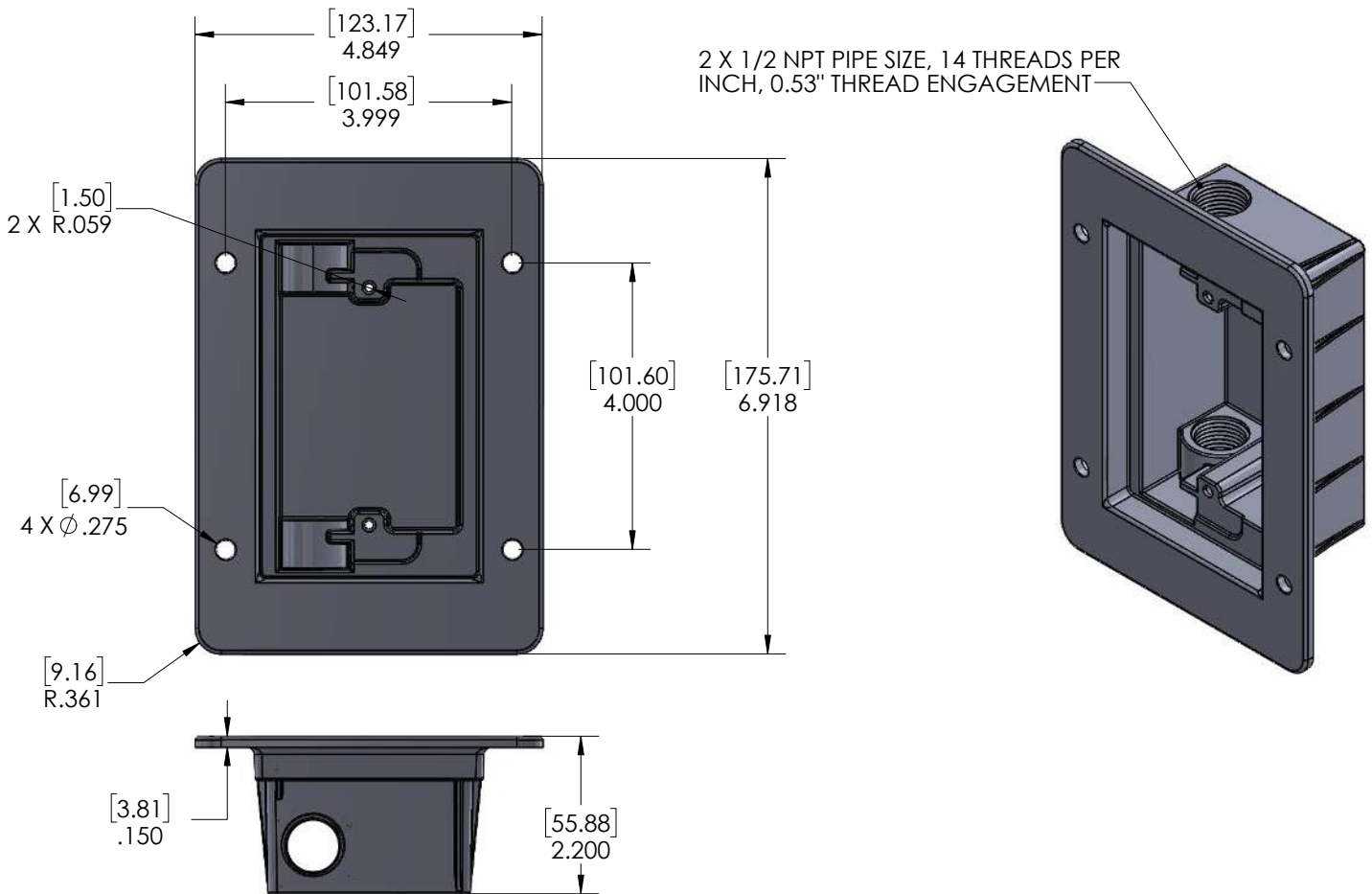

LED Status:

	LED	STATUS
AC Power LED	Green Solid	TAPS unit is functioning
	Orange Solid	TAPS unit is off
Fault LED	Orange Solid	Undervoltage
	Orange Blink	Overvoltage
	Yellow Solid	Over power
	Yellow Blink	Over temperature
	Red Solid	System Fault: Contact Purkeys at 1-800-219-1269 for assistance

Features:

- Patent Pending Dynabalance Technology.....
- Stainless Steel Housing
- Flanged mounting
- LED Indication
- Pure Sinewave AC power
- Extruded aluminum inverter housing.....
- 1500 Watts AC power
- 3000 Watts surge power
- Pre-shut down warning buzzer.....
- Heavy-Duty lug terminals.....
- Temperature controlled fan cooling.....
- Overload protection.....
- Under-voltage protection
- Over-voltage protection.....
- AC Outlets w/Power Indication

Benefits:

- Provide AC power while protecting truck batteries from over discharge
- Protect inverter from the elements
- Easy and secure mounting inside or outside of trailer
- Indicates power or fault
- Powers any AC device, just like AC power in your shop
- Durable and helps dissipate heat quickly
- Plenty of power when you need it
- Plenty of surge power when devices first power on
- Alerts before shutting down due to low voltage
- Allow for easy/robust cable connections
- Unit stays cool
- Inverter protects itself from overload or short circuit
- Inverter protects itself from under voltage
- Inverter protects itself from over voltage
- Plenty of connections for most applications